

turbo 2-20

Ø 2 mm - 23 mm

The bar feeder for bar diameters of 2 mm to 23 mm

The turbo 2-20 operates on the principle known from the turbo-series, namely the two-step feed. By pivoting the pusher, this allows for a compact and thus space-saving design. Its areas of application are Swiss lathes or fixed headstock lathes with a nominal diameter of up to 23 mm which are intended for the operation of small and average diameter ranges.

Bar feeders



Portable control panel with integrated magnetic holders for flexible attachment in the operator's working environment



Guide steady with replaceable guide bushings for the processing of round, square or hexagonal bars

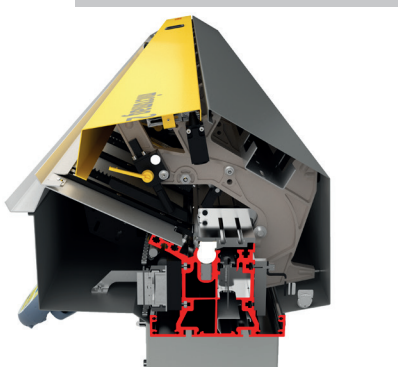

Torsion-resistant machine base made of extruded aluminium allows for optimal vibration dampening

Simple and convenient - the ERGOlogic control ...

- Modern touch control with generously sized 8.4" screen makes an intuitive operating concept possible for a faster learning phase.
- Integrated assistant function for guided set up for inexperienced users.

Efficient and practice-oriented handling ...

- Fast and easy replacement of inserts makes the efficient adaption of the guide channel to different material diameters possible.
- An optional shifting device allows for the bar feeder to be pushed away up to 400mm from the lathe to replace a spindle reduction, for example.

Solid design ...

- The torsion-resistant machine base made of extruded aluminium forms the solid base and guarantees the highest vibration dampening together with inserts made of plastic.

Optimal material bar guidance ...

- When using a movable spindle stock, the synchronized device couples the bar feed of the bar feeder mechanically to the spindle stock via a coupling system and thus guarantees synchronized following of the pusher.
- The guide steady in combination with the following guide tube or telescopic tube guarantee an optimal guidance, even of small bar diameters in a bigger guide channel. For lathes with long travels along the z-axis a following steady rest is offered as additional support of the material bar.

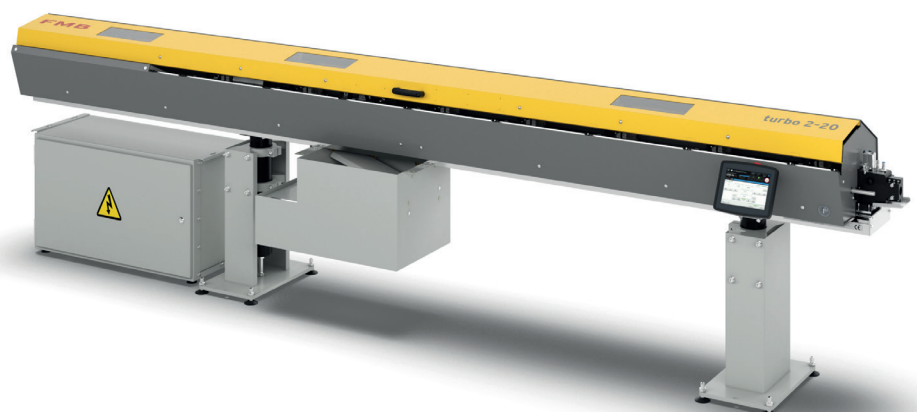

turbo 2-20

The bar feeder for bar diameters of 2 mm to 23 mm

Technical data

Loading possibilities

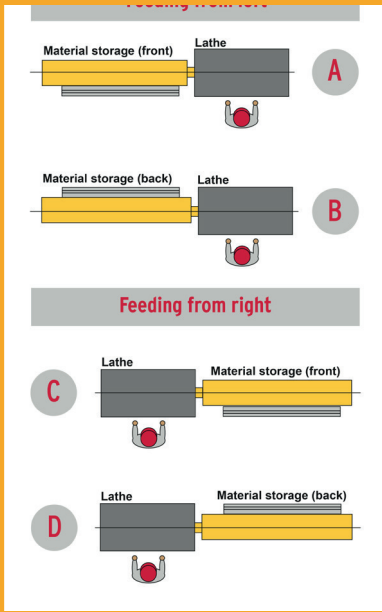

	Units	turbo 2-20		
Ø Pusher (max.)	mm	23		
Bar lengths ¹⁾	mm	2200	3200	4200
Ø Material bars (min. - max.)	mm	2 - 23		
Loading capacity	mm	235		
Loading capacity (min. Ø/max. Ø)	pieces	117 with 2 mm/10 with 23 mm		
Remnant length (max.)	mm	420		
Loading time*	s	-	21	-
Feed speed	mm/s	0 - 750		
Reverse speed	mm/s	0 - 750		
Operating voltage (50/60 Hz)	V	3 x 190 - 480 ²⁾		
Power consumption	kW	1,5		
Compressed air supply	Mpa (bar)	0,6 (6)		
Weight without oil filling	kg	450	550	650

¹⁾ Special lengths upon request.

²⁾ Will be adjusted upon delivery according to specifications of the lathe.

*According to FMB standard cycle.

Preferred capacity adjustment sets

Capacity adjustment set ¹⁾	7	10	15	23
Round D [mm]	2 - 7 ²⁾	3 - 10 ²⁾	8 - 15 ²⁾	12 - 23 ²⁾
Hexagonal AF [mm]	3 - 4	3 - 7	7 - 11	11 - 18
Square AF [mm]	2 - 3	3 - 6	6 - 9	9 - 15

¹⁾ Intermediate sizes upon request.

²⁾ Maximum dimension can only be processed by turning the bar end.

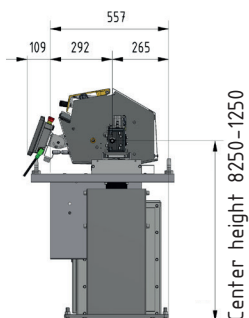

3215 (Bar length 2200)
4215 (Bar length 3200)
5215 (Bar length 4200)

